

FCC EMC Test Report

Project No. : 1810C100A
Equipment : PoE 24+4 port 10G up-link Switch
Test Model : VigorSwitch P2280x
Series Model : VigorSwitch P1280x
Applicant : DrayTek Corp.
Address : No. 26, Fu Shing Rd., HuKou County, Hsin-Chu
Industrial Park, Hsin-Chu, Taiwan R.O.C

Date of Receipt : Oct. 23, 2018
Nov. 26, 2018
Date of Test : Oct. 24, 2018 ~ Nov. 06, 2018
Issued Date : Jan. 24, 2019
Tested by : BTL Inc.

Testing Engineer : Sam. Wang
(Sam Wang)

Technical Manager : Bill Zhang
(Bill Zhang)

Authorized Signatory : Steven Lu
(Steven Lu)

B T L I N C .

No.3, Jinshagang 1st Road, Shixia, Dalang Town, Dongguan,
Guangdong, China.

TEL: +86-769-8318-3000 FAX: +86-769-8319-6000



Certificate #5123.02

Declaration

BTL represents to the client that testing is done in accordance with standard procedures as applicable and that test instruments used has been calibrated with standards traceable to international standard(s) and/or national standard(s).

BTL's reports apply only to the specific samples tested under conditions. It is manufacture's responsibility to ensure that additional production units of this model are manufactured with the identical electrical and mechanical components. **BTL** shall have no liability for any declarations, inferences or generalizations drawn by the client or others from **BTL** issued reports.

The report must not be used by the client to claim product certification, approval, or endorsement by NVLAP, NIST, A2LA, or any agency of the U.S. Government.

This report is the confidential property of the client. As a mutual protection to the clients, the public and ourselves, the test report shall not be reproduced, except in full, without our written approval.

BTL's laboratory quality assurance procedures are in compliance with the **ISO/IEC 17025** requirements, and accredited by the conformity assessment authorities listed in this test report.

BTL is not responsible for the sampling stage, so the results only apply to the sample as received.

The information, data and test plan are provided by manufacturer which may affect the validity of results, so it is manufacturer's responsibility to ensure that the apparatus meets the essential requirements of applied standards and in all the possible configurations as representative of its intended use.

Limitation

For the use of the authority's logo is limited unless the Test Standard(s)/Scope(s)/Item(s) mentioned in this test report is (are) included in the conformity assessment authorities acceptance respective.

Table of Contents	Page
REPORT ISSUED HISTORY	4
1 . GENERAL SUMMARY	5
2 . SUMMARY OF TEST RESULTS	6
2.1 TEST FACILITY	7
2.2 MEASUREMENT UNCERTAINTY	7
3 . GENERAL INFORMATION	8
3.1 GENERAL DESCRIPTION OF EUT	8
3.2 DESCRIPTION OF TEST MODES	8
3.3 EUT OPERATING CONDITIONS	9
3.4 BLOCK DIAGRAM SHOWING THE CONFIGURATION OF SYSTEM TESTED	9
3.5 DESCRIPTION OF SUPPORT UNITS	10
4 . EMC EMISSION TEST	11
4.1 CONDUCTED EMISSION MEASUREMENT	11
4.1.1 POWER LINE CONDUCTED EMISSION	11
4.1.2 MEASUREMENT INSTRUMENTS LIST	11
4.1.3 TEST PROCEDURE	12
4.1.4 DEVIATION FROM TEST STANDARD	12
4.1.5 TEST SETUP	12
4.1.6 TEST RESULTS	12
4.2 RADIATED EMISSION MEASUREMENT	15
4.2.1 LIMITS OF RADIATED EMISSION MEASUREMENT	15
4.2.2 MEASUREMENT INSTRUMENTS LIST	15
4.2.3 TEST PROCEDURE	16
4.2.4 DEVIATION FROM TEST STANDARD	16
4.2.5 TEST SETUP	16
4.2.6 TEST RESULTS-BELOW 1 GHZ	16
5 . EUT TEST PHOTO	19

REPORT ISSUED HISTORY

Report Version	Description	Issued Date
R00	Original Issue. Compared with original test report (BTL-FCCE-1-1810C100), only the applicant, manufacturer, product description, model name and brand name are changed, which does not affect the test results. All rest are kept as same.	Jan. 24, 2019

1. GENERAL SUMMARY

Equipment : PoE 24+4 port 10G up-link Switch
Brand Name : DrayTek Corp.
Test Model : VigorSwitch P2280x
Series Model : VigorSwitch P1280x
Applicant : DrayTek Corp.
Manufacturer : DrayTek Corp.
Address : No. 26, Fu Shing Rd., HuKou County, Hsin-Chu Industrial Park,
Hsin-Chu, Taiwan R.O.C
Factory : Intelligent Technology INC.
Address : Yuanhe 3 Street, Tongsha Industrial Zone, Dongcheng Area, Dongguan,
Guangdong, China
Date of Test : Oct. 24, 2018 ~ Nov. 06, 2018
Test Sample : Engineering Sample No.: D181009536
Standard(s) : FCC Part 15, Subpart B
ICES-003 Issue 6: 2016 (updated April 2017)
ANSI C63.4-2014

The above equipment has been tested and found compliance with the requirement of the relative standards by BTL Inc.

The test data, data evaluation, and equipment configuration contained in our test report (Ref No. BTL-FCCE-1-1810C100A) were obtained utilizing the test procedures, test instruments, test sites that has been accredited by the Authority of A2LA according to the ISO/IEC 17025 quality assessment standard and technical standard(s).

2. SUMMARY OF TEST RESULTS

Test procedures according to the technical standard(s):

EMC Emission				
Standard(s)	Test Item	Limit	Judgment	Remark
FCC Part 15, Subpart B ICES-003 Issue 6: 2016 (updated April 2017) ANSI C63.4-2014	Conducted Emission	Class A	PASS	
	Radiated emission Below 1 GHz	Class A	PASS	
	Radiated emission Above 1 GHz	Class A	N/A	NOTE (1) NOTE (2)

NOTE:

- (1) "N/A" denotes test is not applicable to this device.
- (2) The EUT's max operating frequency is 25 MHz which does not exceed 108 MHz, so the test will not be performed.

2.1 TEST FACILITY

The test facilities used to collect the test data in this report at the location of No.3, Jinshagang 1st Road, Shixia, Dalang Town, Dongguan, Guangdong, China.

BTL's test firm number for FCC: 854385

BTL's designation number for FCC: CN5020

2.2 MEASUREMENT UNCERTAINTY

Where relevant, the following measurement uncertainty levels have been estimated for tests performed on the EUT as specified in CISPR 16-4-2. The BTL measurement uncertainty is less than the CISPR 16-4-2 U_{cispr} requirement.

The reported uncertainty of measurement $y \pm U$, where expanded uncertainty U is based on a standard uncertainty multiplied by a coverage factor of $k=2$, providing a level of confidence of approximately **95%**.

A. Conducted Measurement :

Test Site	Method	Measurement Frequency Range	U, (dB)
DG-C02	CISPR	150 kHz ~ 30MHz	2.32

B. Radiated Measurement :

Test Site	Method	Measurement Frequency Range	Ant. H / V	U, (dB)
DG-CB08 (10m)	CISPR	30MHz ~ 200MHz	V	4.66
		30MHz ~ 200MHz	H	4.64
		200MHz ~ 1,000MHz	V	4.88
		200MHz ~ 1,000MHz	H	4.86

Note: Unless specifically mentioned, the uncertainty of measurement has not been taken into account to declare the compliance or non-compliance to the specification.

3. GENERAL INFORMATION

3.1 GENERAL DESCRIPTION OF EUT

Equipment	PoE 24+4 port 10G up-link Switch
Brand Name	DrayTek Corp.
Test Model	VigorSwitch P2280x
Series Model	VigorSwitch P1280x
Model Difference(s)	Only differ in software.
Power Source	AC Mains.
Power Rating	100V-240VAC,50/60Hz, 5.5A
Connecting I/O Port(s)	1* AC port 24* PoE port 4* Fiber port 1* RS232 port

Note:

1. For a more detailed features description, please refer to the manufacturer's specifications or the user's manual.

3.2 DESCRIPTION OF TEST MODES

To investigate the maximum EMI emission characteristics generated from EUT, the test system was pre-scanning tested base on the consideration of following EUT operation mode or test configuration mode which possible have effect on EMI emission level. Each of these EUT operation mode(s) or test configuration mode(s) mentioned above was evaluated respectively.

Pretest Mode	Description
Mode 1	FULL SYSTEM

For Conducted Test	
Final Test Mode	Description
Mode 1	FULL SYSTEM

For Radiated Test	
Final Test Mode	Description
Mode 1	FULL SYSTEM

3.3 EUT OPERATING CONDITIONS

The EUT exercise program used during radiated and/or conducted emission measurement was designed to exercise the various system components in a manner similar to a typical use. The standard test signals and output signal as following:

- PoE port 1-24 connected to PoE LOAD via RJ45 cable. PoE LOAD LAN port connected to notebook(B&C) via RJ45 cable. Notebook(B&C) perform "Ping.exe" to conduct data communication.
- Fiber port 25-28 connected to switch via fiber cable.

3.4 BLOCK DIAGRAM SHOWING THE CONFIGURATION OF SYSTEM TESTED

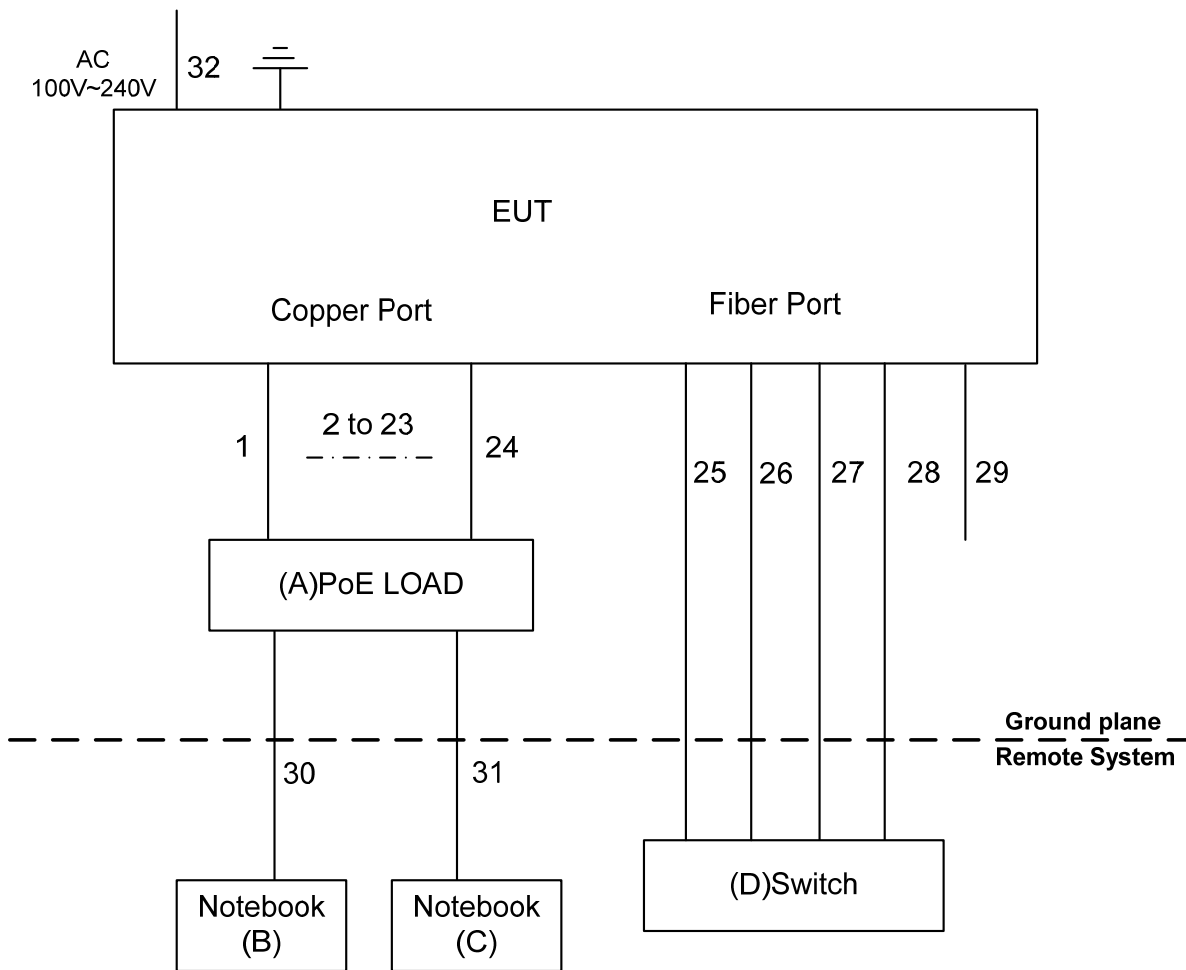

3.5 DESCRIPTION OF SUPPORT UNITS

The EUT has been tested as an independent unit together with other necessary accessories or support units. The following support units or accessories were used to form a representative test configuration during the tests.

Item	Equipment	Mfr/Brand	Model/Type No.	Series No.
A	PoE Load	N/A	N/A	N/A
B	Notebook	HP	Hstnn-169c-3	CNU02203XG
C	Notebook	Lenovo	E46L	EB21809870
D	Switch	D-LINK	DGS-3130-54PS	N/A

Item	Shielded Type	Ferrite Core	Length	Note
1-24	NO	NO	1.5m	RJ45 Cable
25	NO	NO	10m	Fiber Cable
26	NO	NO	10m	Fiber Cable
27	NO	NO	10m	Fiber Cable
28	NO	NO	10m	Fiber Cable
29	YES	NO	1.8m	RS232 Cable
30	NO	NO	10m	RJ45 Cable
31	NO	NO	10m	RJ45 Cable
32	NO	NO	1.8m	AC Cable

4. EMC EMISSION TEST

4.1 CONDUCTED EMISSION MEASUREMENT

4.1.1 POWER LINE CONDUCTED EMISSION (FREQUENCY RANGE 150KHZ-30MHZ)

FREQUENCY (MHz)	Class A (dBuV)		Class B (dBuV)	
	Quasi-peak	Average	Quasi-peak	Average
0.15 - 0.5	79.00	66.00	66 - 56 *	56 - 46 *
0.50 - 5.0	73.00	60.00	56.00	46.00
5.0 - 30.0	73.00	60.00	60.00	50.00

Note:

- (1) The tighter limit applies at the band edges.
- (2) The limit of " * " marked band means the limitation decreases linearly with the logarithm of the frequency in the range.
- (3) The test result calculated as following:
 Measurement Value = Reading Level + Correct Factor
 Correct Factor = Insertion Loss + Cable Loss + Attenuator Factor(if use)
 Margin Level = Measurement Value - Limit Value

4.1.2 MEASUREMENT INSTRUMENTS LIST

Item	Kind of Equipment	Manufacturer	Type No.	Serial No.	Calibrated until
1	Measurement Software	Farad	EZ-EMC Ver.NB-03A 1-01	N/A	N/A
2	Cable	N/A	RG223	12m	Mar. 23, 2019
3	LISN	EMCO	3816/2	00052765	Mar. 11, 2019
4	50Ω Terminator	SHX	TF2-3G-A	08122901	Mar. 11, 2019
5	TWO-LINE V-NETWORK	R&S	ENV216	101447	Mar. 11, 2019
6	EMI Test Receiver	R&S	ESCI	100382	Mar. 11, 2019

Remark: "N/A" denotes no model name, serial no. or calibration specified.

All calibration period of equipment list is one year.

4.1.3 TEST PROCEDURE

- a. The EUT was placed 0.8 meters from the horizontal ground plane with EUT being connected to the power mains through a line impedance stabilization network (LISN). All other support equipments powered from additional LISN(s). The LISN provide 50 Ohm/ 50uH of coupling impedance for the measuring instrument.
- b. Interconnecting cables that hang closer than 40 cm to the ground plane shall be folded back and forth in the center forming a bundle 30 to 40 cm long.
- c. I/O cables that are not connected to a peripheral shall be bundled in the center. The end of the cable may be terminated, if required, using the correct terminating impedance. The overall length shall not exceed 1 m.
- d. LISN at least 80 cm from nearest part of EUT chassis.
- e. For the actual test configuration, please refer to the related Item –EUT Test Photos.
- f. First the whole spectrum of emission caused by equipment under test(EUT) is recorded with Detector set to peak. Peak value recorded in table if the margin from QP Limit is larger than 2dB, otherwise, QP value is recorded, Measuring frequency range from 150KHz to 30MHz.

4.1.4 DEVIATION FROM TEST STANDARD

No deviation

4.1.5 TEST SETUP

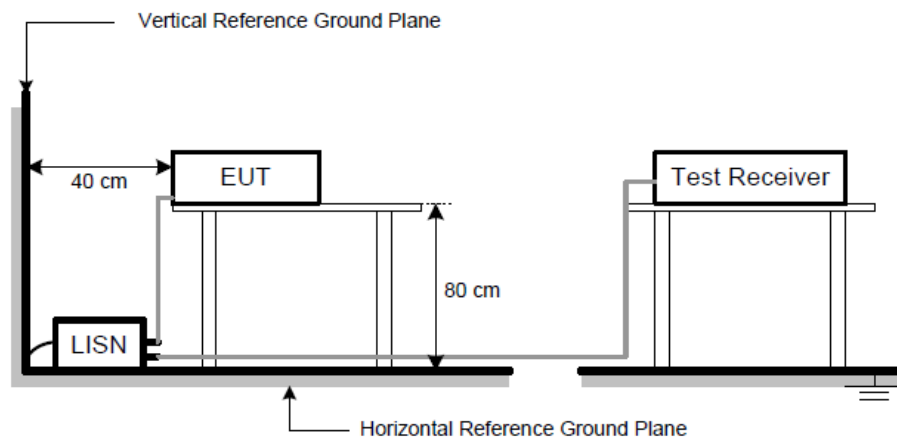

4.1.6 TEST RESULTS

Remark

- (1) Reading in which marked as QP means measurements by using are Quasi-Peak Mode with Detector BW=9 kHz; SPA setting in RBW=10 kHz, VBW =10 kHz, Swp. Time = 0.3 sec./MHz. Reading in which marked as AV means measurements by using are Average Mode with instrument setting in RBW=10 kHz, VBW=10 kHz, Swp. Time =0.3 sec./MHz.
- (2) All readings are QP Mode value unless otherwise stated AVG in column of 『Note』. If the QP Mode Measured value compliance with the QP Limits and lower than AVG Limits, the EUT shall be deemed to meet both QP & AVG Limits and then only QP Mode was measured, but AVG Mode didn't perform. In this case, a “ * ” marked in AVG Mode column of Interference Voltage Measured.

EUT	PoE 24+4 port 10G up-link Switch	Model Name	VigorSwitch P2280x
Temperature	27°C	Relative Humidity	39%
Test Voltage	AC 120V/60Hz	Phase	Line
Test Mode	FULL SYSTEM		
Test Engineer	Sam Wang		

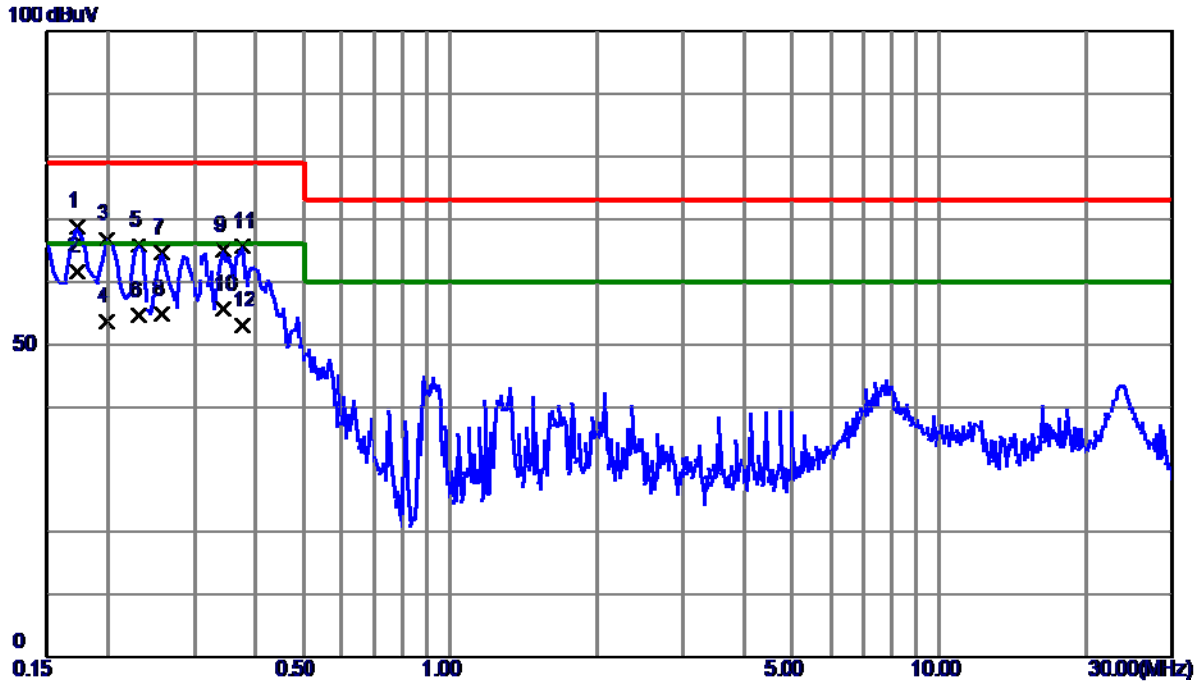

No.	Freq. MHz	Reading Level dBuV	Correct Factor dB	Measurement dBuV	Limit dBuV	Margin dB	Detector
1	0.1725	59.06	9.82	68.88	79.00	-10.12	QP
2 *	0.1725	51.70	9.82	61.52	66.00	-4.48	AVG
3	0.1995	56.97	9.82	66.79	79.00	-12.21	QP
4	0.1995	43.85	9.82	53.67	66.00	-12.33	AVG
5	0.2310	56.03	9.82	65.85	79.00	-13.15	QP
6	0.2310	44.85	9.82	54.67	66.00	-11.33	AVG
7	0.2580	54.74	9.82	64.56	79.00	-14.44	QP
8	0.2580	44.96	9.82	54.78	66.00	-11.22	AVG
9	0.3435	55.24	9.81	65.05	79.00	-13.95	QP
10	0.3435	45.85	9.81	55.66	66.00	-10.34	AVG
11	0.3750	55.72	9.81	65.53	79.00	-13.47	QP
12	0.3750	43.15	9.81	52.96	66.00	-13.04	AVG

EUT	PoE 24+4 port 10G up-link Switch	Model Name	VigorSwitch P2280x
Temperature	27°C	Relative Humidity	39%
Test Voltage	AC 120V/60Hz	Phase	Neutral
Test Mode	FULL SYSTEM		
Test Engineer	Sam Wang		

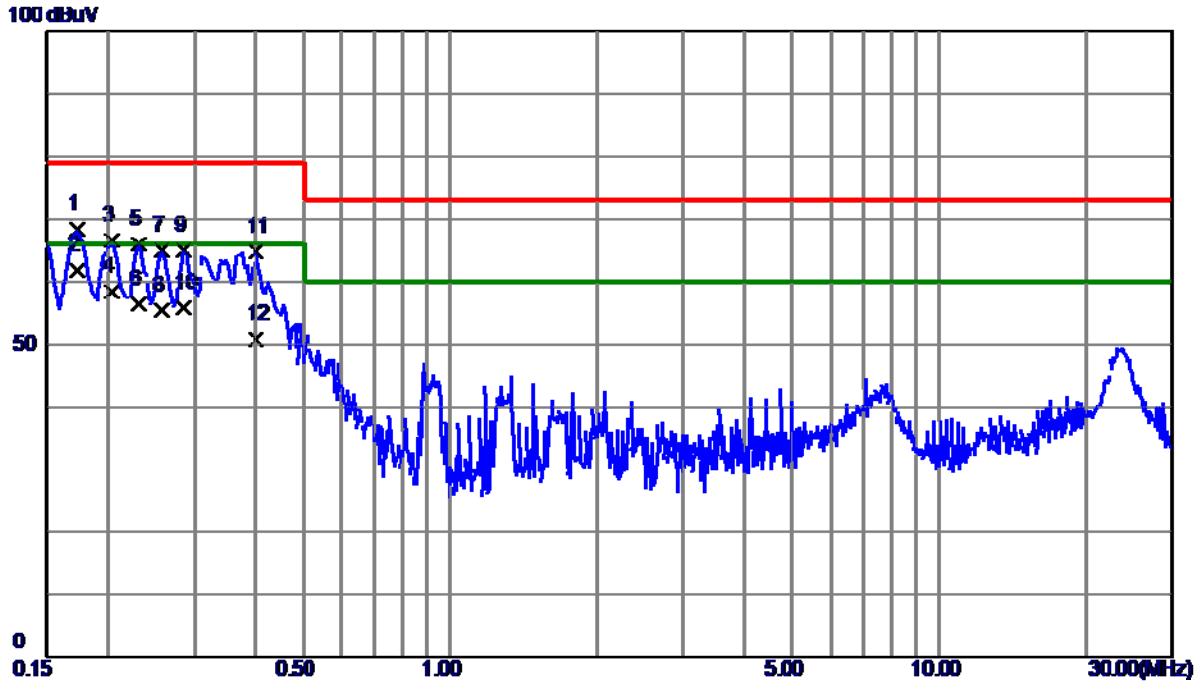

No.	Freq. MHz	Reading Level dBuV	Correct Factor dB	Measurement dBuV	Limit dBuV	Margin dB	Detector
1	0.1725	58.47	9.91	68.38	79.00	-10.62	QP
2 *	0.1725	51.80	9.91	61.71	66.00	-4.29	AVG
3	0.2040	56.75	9.91	66.66	79.00	-12.34	QP
4	0.2040	48.52	9.91	58.43	66.00	-7.57	AVG
5	0.2310	56.09	9.92	66.01	79.00	-12.99	QP
6	0.2310	46.51	9.92	56.43	66.00	-9.57	AVG
7	0.2580	55.09	9.92	65.01	79.00	-13.99	QP
8	0.2580	45.52	9.92	55.44	66.00	-10.56	AVG
9	0.2850	55.04	9.93	64.97	79.00	-14.03	QP
10	0.2850	45.84	9.93	55.77	66.00	-10.23	AVG
11	0.4020	54.83	9.95	64.78	79.00	-14.22	QP
12	0.4020	40.80	9.95	50.75	66.00	-15.25	AVG

4.2 RADIATED EMISSION MEASUREMENT

4.2.1 LIMITS OF RADIATED EMISSION MEASUREMENT

Below 1 GHz

Measurement Method and Applied Limits:

ANSI C63.4:

Frequency (MHz)	Class A (at 10m)		Class B (at 3m)	
	(uV/m) Field strength	(dBuV/m) Field strength	(uV/m) Field strength	(dBuV/m) Field strength
30 - 88	90	39	100	40
88 - 216	150	43.5	150	43.5
216 - 960	210	46.4	200	46
Above 960	300	49.5	500	54

NOTE:

- (1) The limit for radiated test was performed according to as following:
FCC Part 15, Subpart B
- (2) The tighter limit applies at the band edges.
- (3) Emission level (dBuV/m) = 20log Emission level (uV/m).
3m Emission level = 10m Emission level + 20log(10m/3m).
- (4) The test result calculated as following:
Measurement Value = Reading Level + Correct Factor
Correct Factor = Antenna Factor + Cable Loss - Amplifier Gain(if use)
Margin Level = Measurement Value - Limit Value

4.2.2 MEASUREMENT INSTRUMENTS LIST

Below 1GHz:

Item	Kind of Equipment	Manufacturer	Type No.	Serial No.	Calibrated until
1	Receiver	Keysight	N9038A	MY54450004	Aug. 11, 2019
2	MXE EMI Receiver	Agilent	N9038A	MY53220133	Mar. 11, 2019
3	Pre-Amplifier	Mini-Circuits	EMC 9135	980284	Mar. 11, 2019
4	Pre-Amplifier	Mini-Circuits	EMC 9135	980283	Mar. 11, 2019
5	Trilog-Broadband Antenna	Schwarzbeck	VULB9168	586	Nov. 09, 2018
6	Trilog-Broadband Antenna	Schwarzbeck	VULB9168	587	Jan. 04, 2019
7	Cable	emci	LMR-400(5m+11m+15m)	N/A	Jan. 11, 2019
8	Cable	emci	LMR-400(5m+8m+15m)	N/A	Jan. 11, 2019
9	Measurement Software	Farad	EZ-EMC Ver.BTL-2ANT-1	N/A	N/A
10	Multi-Device Controller	ETS-Lindgren	2090	N/A	N/A
11	Attenuator	SHX	TS2-6dB-6G-A	16101101	Nov. 09, 2018
12	Attenuator	SHX	TS2-6dB-6G-A	16101102	Jan. 04, 2019

Remark: "N/A" denotes no model name, no serial no. or no calibration specified.

All calibration period of equipment list is one year.

4.2.3 TEST PROCEDURE

- The measuring distance of 10 m shall be used for measurements. The EUT was placed on the top of a rotating table 0.8 meter above the ground at a 10 meter semi-anechoic chamber. The table was rotated 360 degrees to determine the position of the highest radiation.(below 1 GHz)
- The height of the equipment or of the substitution antenna shall be 0.8 m, the height of the test antenna shall vary between 1 m to 4 m. Both horizontal and vertical polarizations of the antenna are set to make the measurement.
- For each suspected emission, the EUT was arranged to its worst case and then the antenna was tuned to heights find the maximum reading (used Bore sight function).
- The receiver system was set to peak and average detect function and specified bandwidth with maximum hold mode when the test frequency is above 1 GHz.
- The initial step in collecting radiated emission data is a receiver peak detector mode pre-scanning the measurement frequency range. Significant peaks are then marked and then Quasi Peak detector mode re-measured.
- All readings are Peak unless otherwise stated QP in column of Note. Peak denotes that the Peak reading compliance with the QP Limits and then QP Mode measurement didn't perform. (below 1GHz)
- For the actual test configuration, please refer to the related Item - Block Diagram of system tested (please refer to 3.3).

4.2.4 DEVIATION FROM TEST STANDARD

No deviation

4.2.5 TEST SETUP

(A) Radiated Emission Test Set-Up Frequency Below 1 GHz

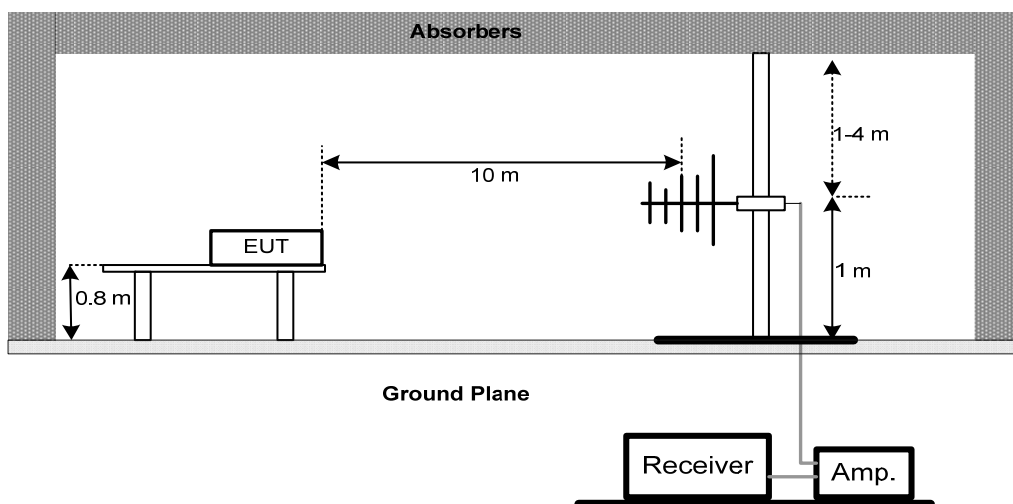

4.2.6 TEST RESULTS-BELOW 1 GHZ

Remark :

- All readings are Peak unless otherwise stated QP in column of 『 Note 』 . Peak denotes that the Peak reading compliance with the QP Limits and then QP Mode measurement didn't perform.
- Measuring frequency range from 30 MHz to 1000 MHz
- If the peak scan value lower limit more than 20 dB, then this signal data does not show in table.

EUT	PoE 24+4 port 10G up-link Switch	Model Name	VigorSwitch P2280x
Temperature	25°C	Relative Humidity	60%
Test Voltage	AC 120V/60Hz	Polarization	Vertical
Test Mode	FULL SYSTEM		
Test Engineer	Sam Wang		

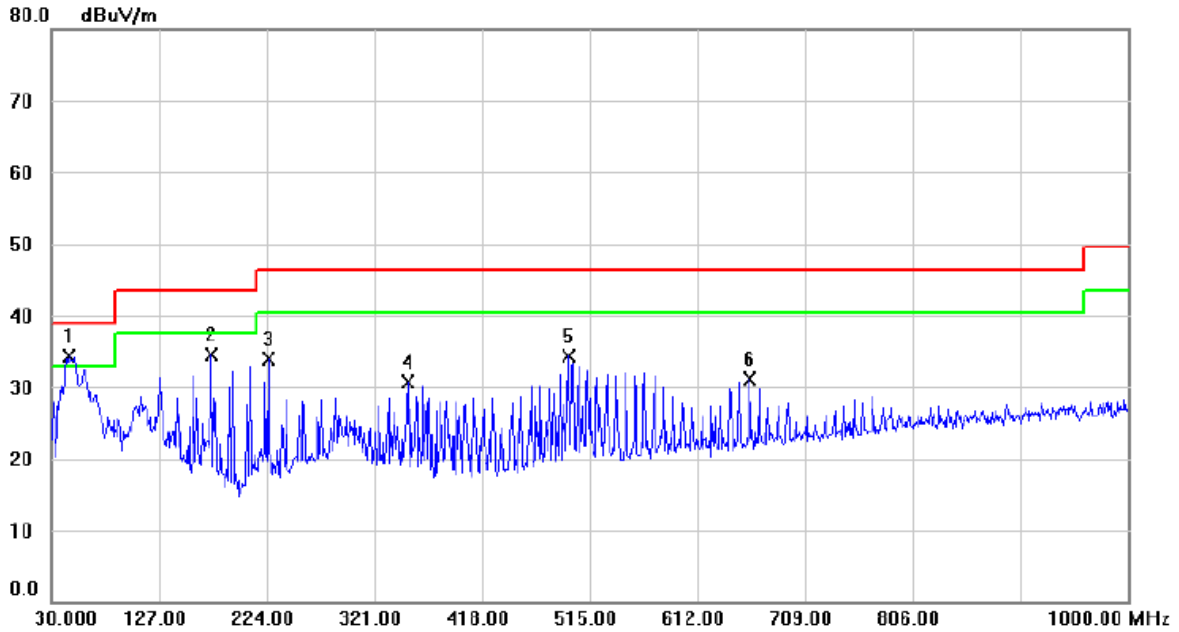

No.	Mk.	Freq. MHz	Reading Level dBuV	Correct Factor dB	Measure- ment dBuV/m	Limit dBuV/m	Margin dB	Detector	Comment
1	*	45.5200	51.69	-17.39	34.30	39.00	-4.70	QP	
2		174.5300	51.64	-17.12	34.52	43.50	-8.98	QP	
3		225.4550	52.31	-18.38	33.93	46.40	-12.47	QP	
4		351.0700	44.62	-13.96	30.66	46.40	-15.74	QP	
5		496.5700	44.84	-10.61	34.23	46.40	-12.17	QP	
6		659.0450	38.79	-7.77	31.02	46.40	-15.38	QP	

EUT	PoE 24+4 port 10G up-link Switch	Model Name	VigorSwitch P2280x
Temperature	25°C	Relative Humidity	60%
Test Voltage	AC 120V/60Hz	Polarization	Horizontal
Test Mode	FULL SYSTEM		
Test Engineer	Sam Wang		

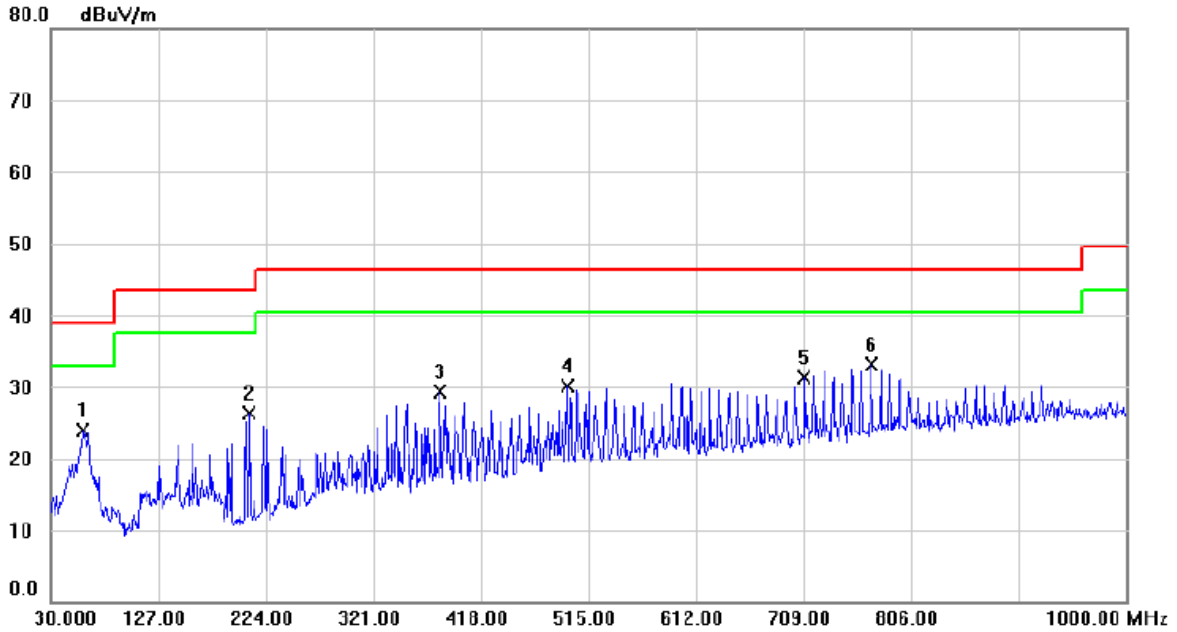

No.	Mk.	Freq. MHz	Reading Level dBuV	Correct Factor dB	Measure- ment dBuV/m	Limit dBuV/m	Margin dB	Detector	Comment
1		59.1000	41.08	-17.20	23.88	39.00	-15.12	QP	
2		209.4500	45.44	-19.11	26.33	43.50	-17.17	QP	
3		381.1400	42.71	-13.39	29.32	46.40	-17.08	QP	
4		496.5700	40.70	-10.54	30.16	46.40	-16.24	QP	
5		709.9700	38.78	-7.54	31.24	46.40	-15.16	QP	
6	*	770.1100	39.50	-6.42	33.08	46.40	-13.32	QP	

5. EUT TEST PHOTO

Conducted Emission



Radiated emission below 1 GHz

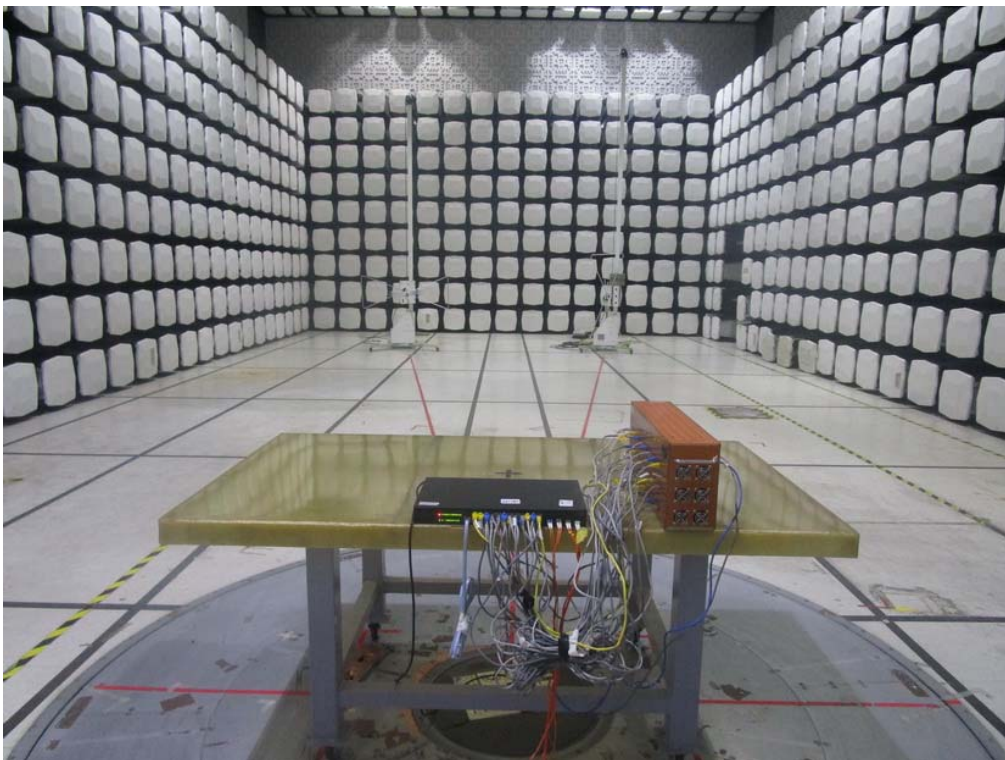
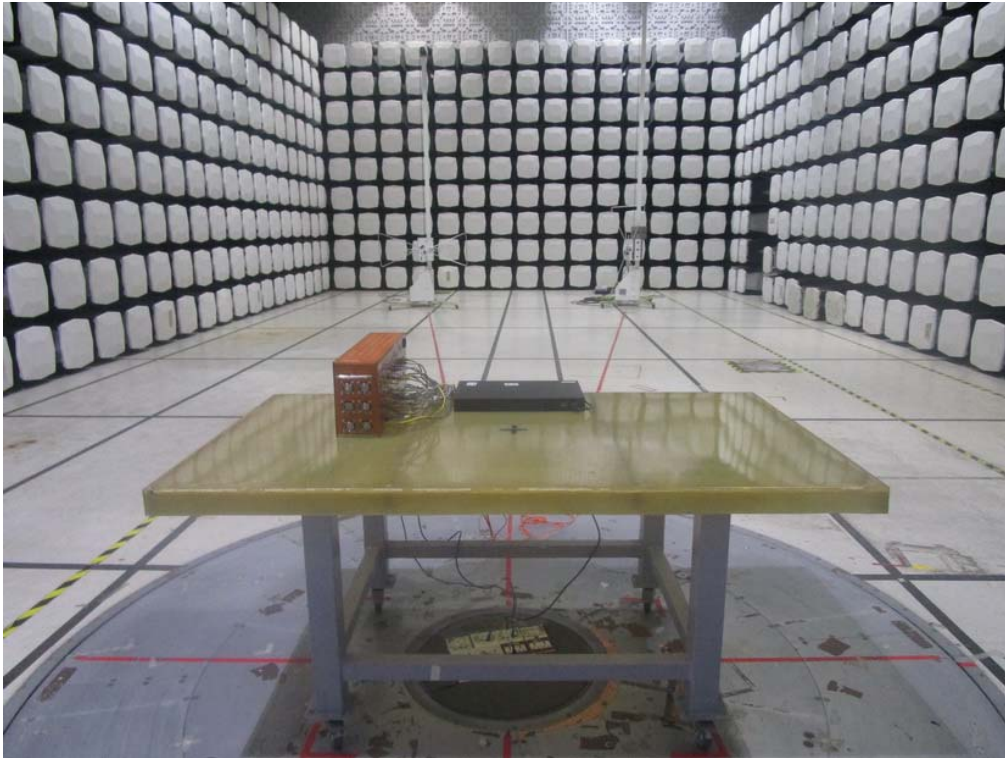

End of Test Report