



FCC 47 CFR PART 15 SUBPART B & IC ICES-003 TEST REPORT

for

Multi-WAN Security Appliance

MODEL: Vigor3900

Test Report Number:

T101001005-D

Issued for

DrayTek Corp.

**No.26, Fu Shing Rd., HuKou County,
Hsin-Chu Industrial Park, Hsin-Chu, Taiwan 303 R.O.C.**

Issued By:

Compliance Certification Services Inc.

Wugu Laboratory

No. 11, Wu-Gong 6th Rd., Wugu Industrial Park,
Taipei Hsien 248, Taiwan (R.O.C.)

TEL: 886-2-2299-9720

FAX: 886-2-2299-9721

E-Mail: service@ccsrf.com

Issued Date: November 30, 2010



Note: This report shall not be reproduced except in full, without the written approval of Compliance Certification Services Inc. This document may be altered or revised by Compliance Certification Services Inc. personnel only, and shall be noted in the revision section of the document. The client should not use it to claim product endorsement by TAF, A2LA, NIST or any government agencies. The test results in the report only apply to the tested sample.



Revision History

Rev.	Issue Date	Revisions	Effect Page	Revised By
00	November 30, 2010	Initial Issue	ALL	Angel Cheng



TABLE OF CONTENTS

1 TEST RESULT CERTIFICATION4

2 EUT DESCRIPTION5

3 TEST METHODOLOGY6

 3.1. DECISION OF FINAL TEST MODE6

 3.2. EUT SYSTEM OPERATION6

4 SETUP OF EQUIPMENT UNDER TEST7

 4.1. DESCRIPTION OF SUPPORT UNITS7

 4.2. CONFIGURATION OF SYSTEM UNDER TEST8

5 FACILITIES AND ACCREDITATIONS9

 5.1. FACILITIES9

 5.2. ACCREDITATIONS9

 5.3. MEASUREMENT UNCERTAINTY10

6 CONDUCTED EMISSION MEASUREMENT11

 6.1. LIMITS OF CONDUCTED EMISSION MEASUREMENT11

 6.2. TEST INSTRUMENTS11

 6.3. TEST PROCEDURES12

 6.4. TEST SETUP13

 6.5. DATA SAMPLE:13

 6.6. TEST RESULTS14

7 RADIATED EMISSION MEASUREMENT16

 7.1. LIMITS OF RADIATED EMISSION MEASUREMENT16

 7.2. TEST INSTRUMENTS18

 7.3. TEST PROCEDURES19

 7.4. TEST SETUP20

 7.5. DATA SAMPLE:20

 7.6. TEST RESULTS22

8 PHOTOGRAPHS OF THE TEST CONFIGURATION26

APPENDIX 1 - PHOTOGRAPHS OF EUT



1 TEST RESULT CERTIFICATION

Product:	Multi-WAN Security Appliance
Model:	Vigor3900
Brand:	DrayTek
Applicant:	DrayTek Corp. No.26, Fu Shing Rd., HuKou County, Hsin-Chu Industrial Park, Hsin-Chu, Taiwan 303 R.O.C.
Manufacturer:	DrayTek Corp. No.26, Fu Shing Rd., HuKou County, Hsin-Chu Industrial Park, Hsin-Chu, Taiwan 303 R.O.C.
Tested:	October 21 ~ November 19, 2010
Test Voltage:	120VAC, 60Hz

EMISSION			
Standard	Item	Result	Remarks
FCC 47 CFR Part 15 Subpart B (October 1, 2009), ICES-003 Issue 4: 2004 ANSI C63.4-2003	Conducted (Power Port)	PASS	Meet Class A limit
	Radiated	PASS	Meet Class A limit

Note: 1. The statements of test result on the above are decided by the request of test standard only; the measurement uncertainties are not factored into this compliance determination.
2. The information of measurement uncertainty is available upon the customer's request.

Deviation from Applicable Standard
None

The above equipment has been tested by Compliance Certification Services Inc., and found compliance with the requirements set forth in the technical standards mentioned above. The results of testing in this report apply only to the product/system, which was tested. Other similar equipment will not necessarily produce the same results due to production tolerance and measurement uncertainties.

Approved by:

Reviewed by:

Rex Lai
Section Manager

Gina Lo
Section Manager



2 EUT DESCRIPTION

Product	Multi-WAN Security Appliance
Brand Name	DrayTek
Model	Vigor3900
Applicant	DrayTek Corp.
Serial Number	T101001005
Received Date	October 1, 2010
EUT Power Rating	AC 100-240V, 50-60Hz,0.5A MAX

I/O Port

I/O PORT TYPES	Q'TY	TESTED WITH
1). USB Port	2	2
2). Giga WAN Port	4	4
3). Giga LAN Port	2	2
4). Console Port	1	1
5). SFP Port	2	2



3 TEST METHODOLOGY

3.1. DECISION OF FINAL TEST MODE

1. The following test mode was scanned during the preliminary test:

Pre-Test Mode
Mode 1: Operating

2. After the preliminary scan, the following test mode was found to produce the highest emission level.

Final Test Mode		
Emission	Conducted Emission	Mode 1
	Radiated Emission	Mode 1

Then, the above highest emission mode of the configuration of the EUT and cable was chosen for all final test items.

3.2. EUT SYSTEM OPERATION

- 1 Setup the EUT and simulators as shown on 4.2.
- 2 Turn on the power of all equipment.
- 3 The EUT will receive the RF signal source and shown it on the screen.
- 4 Repeat the above procedure (3).

Note: Test program is self-repeating throughout the test.



4 SETUP OF EQUIPMENT UNDER TEST

4.1. DESCRIPTION OF SUPPORT UNITS

The EUT has been tested as an independent unit together with other necessary accessories or support units. The following support units or accessories were used to form a representative test configuration during the tests.

No.	Device Type	Brand	Model	Series No.	FCC ID	Data Cable	Power Cord
1.	320GB 2.5" HDD	Seagate	9ZA2MG-500	538224 2818	FCC DoC	Shielded, 1.8m	N/A
2.	320GB 2.5" HDD	Seagate	9ZA2MG-500	538224 2819	FCC DoC	Shielded, 1.8m	N/A
3	Notebook PC (Remote)	IBM	1951-I3V(T60)	L3B2188	FCC DoC	LAN Cable: Unshielded, 10m	AC I/P: Unshielded, 1.8m DC O/P: Unshielded, 1.8m with a core
4	Notebook PC (Remote)	IBM	2672 (X31)	99PBTKB	FCC DoC	LAN Cable: Unshielded, 10m	AC I/P: Unshielded, 1.8m DC O/P: Unshielded, 1.8m with a core

Note: Grounding was established in accordance with the manufacturer's requirements and conditions for the intended use.



4.2. CONFIGURATION OF SYSTEM UNDER TEST

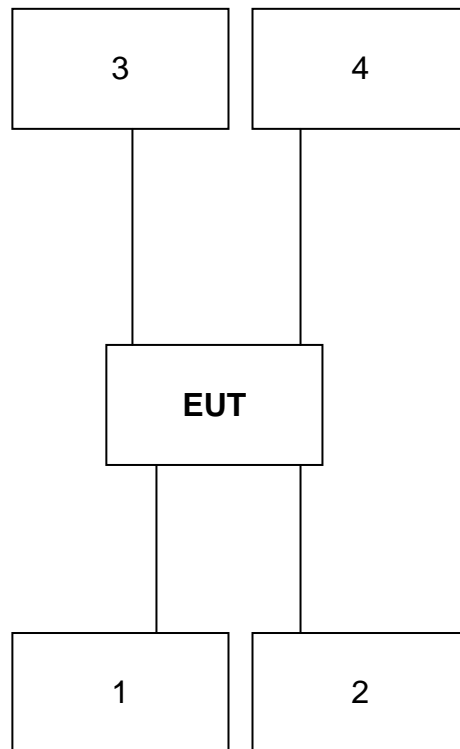



5 FACILITIES AND ACCREDITATIONS

5.1. FACILITIES

All measurement facilities used to collect the measurement data are located at:

- No.11, Wugong 6th Rd., Wugu Industrial Park, Taipei Hsien 248, Taiwan
- No.139, Wugong Rd., Wugu Industrial Park, Taipei Hsien 248, Taiwan
- No. 81-1, Lane 210, Pa-De 2nd Rd., Luchu Hsiang, Taoyuan Shien, Taiwan.
- No.163-1, Jhongsheng Rd., Sindian City, Taipei County 23151, Taiwan.

The sites are constructed in conformance with the requirements of ANSI C63.4 and CISPR 22. All receiving equipment conforms to CISPR 16-1-1, CISPR 16-1-2, CISPR 16-1-3, CISPR 16-1-4, CISPR 16-1-5.

5.2. ACCREDITATIONS

Our laboratories are accredited and approved by the following approval agencies according to ISO/IEC 17025.

Taiwan	TAF (TAF 1309)
USA	A2LA (0824.01)

The measuring facility of laboratories has been authorized or registered by the following approval agencies.

Canada	Industry Canada (3M Semi Anechoic Chamber: IC 2324G-1 / IC 2324G-2 / 2324J-1 / 2324J-2 to perform)
Norway	Nemko
Japan	VCCI 966 Chamber C: Radiated emissions: 30 MHz -1000 MHz: R-3282 / Above 1GHz: G-146 10M Chamber: Radiated emissions: 30 MHz -1000 MHz: R-3283 / Above 1GHz: G-147 Conducted Emission A: C-3612 / T-1745
USA	FCC (3M Semi Anechoic Chamber (FCC MRA: TW1039) to perform FCC Part 15 measurements)

Copies of granted accreditation certificates are available for downloading from our web site, <http://www.ccsrf.com>



5.3. MEASUREMENT UNCERTAINTY

Where relevant, the following measurement uncertainty levels have been estimated for tests performed on the EUT as specified in CISPR 16-4-2:

Measurement	Frequency	Uncertainty
Conducted emissions	9kHz~30MHz	±1.6516
Radiated emissions	30~200MHz	±3.9642
	200~1000MHz	±3.9510
	Above 1GHz	±2.4656

This uncertainty represents an expanded uncertainty expressed at approximately the 95% confidence level using a coverage factor of $k=2$.

Consistent with industry standard (e.g. CISPR 22: 2006, clause 11, Measurement Uncertainty) determining compliance with the limits shall be based on the results of the compliance measurement. Consequently the measured emissions being less than the maximum allowed emission result in this being a compliant test or passing test.

The acceptable measurement uncertainty value without requiring revision of the compliance statement is based on conducted and radiated emissions being less than U_{CISPR} which is 3.6dB and 5.2dB respectively. CCS values (called U_{Lab} in CISPR 16-4-2) is less than U_{CISPR} as shown in the table above. Therefore, MU need not be considered for compliance.



6 CONDUCTED EMISSION MEASUREMENT

6.1. LIMITS OF CONDUCTED EMISSION MEASUREMENT

FREQUENCY (MHz)	Class A (dBuV)		Class B (dBuV)	
	Quasi-peak	Average	Quasi-peak	Average
0.15 - 0.5	79	66	66 - 56	56 - 46
0.50 - 5.0	73	60	56	46
5.0 - 30.0	73	60	60	50

NOTE:

- (1) The lower limit shall apply at the transition frequencies.
- (2) The limit decreases in line with the logarithm of the frequency in the range 0.15 to 0.50 MHz.
- (3) All emanations from a class A/B digital device or system, including any network of conductors and apparatus connected thereto, shall not exceed the level of field strengths specified above.

6.2. TEST INSTRUMENTS

Conducted Emission Room # B				
Name of Equipment	Manufacturer	Model	Serial Number	Calibration Due
EMI Test Receiver	R&S	ESCI	101073	07/15/2011
LISN	R&S	ENV216	101054	04/28/2011
LISN	FCC	FCC-LISN-50/250-16-2-07	06012	11/28/2011
ISN	FCC	FCC-TLISN-T2-02-09	100105	02/16/2011
ISN	FCC	FCC-TLISN-T8-02-09	100106	02/16/2011
Current Probe	TEGAM	95236-1	12567	03/22/2011
Capacitive Voltage Probe	FCC	F-CVP-1	100185	02/17/2011
Test S/W	CCS-3A1-CE			

NOTE: The calibration interval of the above test instruments is 12 months and the calibrations are traceable to NML/ROC and NIST/USA.



6.3. TEST PROCEDURES

(please refer to measurement standard or CCS SOP PA-031)

Procedure of Preliminary Test

- The EUT and support equipment, if needed, were set up as per the test configuration to simulate typical usage per the user's manual. When the EUT is a tabletop system, a wooden table with a height of 0.8 meters is used and is placed on the ground plane as per ANSI C63.4 (see Test Facility for the dimensions of the ground plane used). When the EUT is a floor standing equipment, it is placed on the ground plane, which has a 12 mm non-conductive covering to insulate the EUT from the ground plane.
- All I/O cables were positioned to simulate typical actual usage as per ANSI C63.4.
- The test equipment EUT installed by AC 120VAC/60Hz main power, through a Line Impedance Stabilization Network (LISN), which was supplied power source and was grounded to the ground plane.
- All support equipment power by from a second LISN.
- The test program of the EUT was started. Emissions were measured on each current carrying line of the EUT using an EMI Test Receiver connected to the LISN powering the EUT.
- The Receiver scanned from 150kHz to 30MHz for emissions in each of the test modes.
- During the above scans, the emissions were maximized by cable manipulation.
- The test mode(s) described in Item 3.1 were scanned during the preliminary test.
- After the preliminary scan, we found the test mode described in Item 3.1 producing the highest emission level.
- The worst configuration of EUT and cable of the above highest emission level were recorded for reference of the final test.

Procedure of Final Test

- EUT and support equipment were set up on the test bench as per the configuration with highest emission level in the preliminary test.
- A scan was taken on both power lines, Line 1 and Line 2, recording at least the six highest emissions. Emission frequency and amplitude were recorded into a computer in which correction factors were used to calculate the emission level and compare reading to the applicable limit.
- The test data of the worst-case condition(s) was recorded.

6.4. TEST SETUP

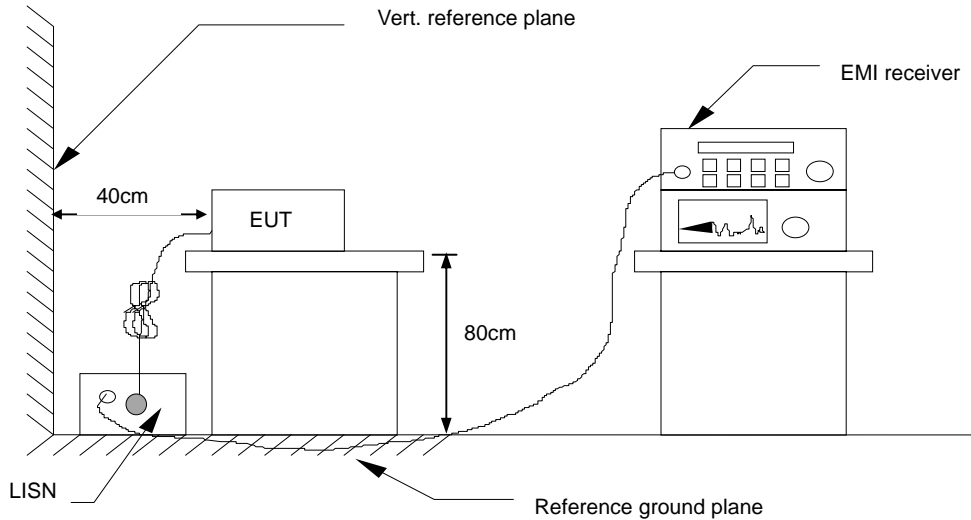

- For the actual test configuration, please refer to the related item – Photographs of the Test Configuration.

6.5. DATA SAMPLE:

Frequency (MHz)	QuasiPeak reading (dBuV)	Average reading (dBuV)	Correction factor (dB)	QuasiPeak result (dBuV)	Average result (dBuV)	QuasiPeak limit (dBuV)	Average limit (dBuV)	QuasiPeak margin (dB)	Average margin (dB)	Remark
x.xx	43.95	33.00	10.00	53.95	43.00	56.00	46.00	-2.05	-3.00	Pass

Frequency (MHz) = Emission frequency in MHz
 Reading (dBuV) = Uncorrected Analyzer/Receiver reading + Insertion loss of LISN, if it > 0.5 dB
 Correction Factor (dB) = LISN Factor + Cable Loss
 Result (dBuV) = Raw reading converted to dBuV and CF added
 Limit (dBuV) = Limit stated in standard
 Margin (dB) = Result (dBuV) – Limit (dBuV)



6.6. TEST RESULTS

CCS Conduction Test

Model No.	Vigor3900	Test Date	2010/10/21
Environmental Conditions	26°C, 60% RH	Test Mode	Mode 1
Tested by	Hank Wang	Line	L1

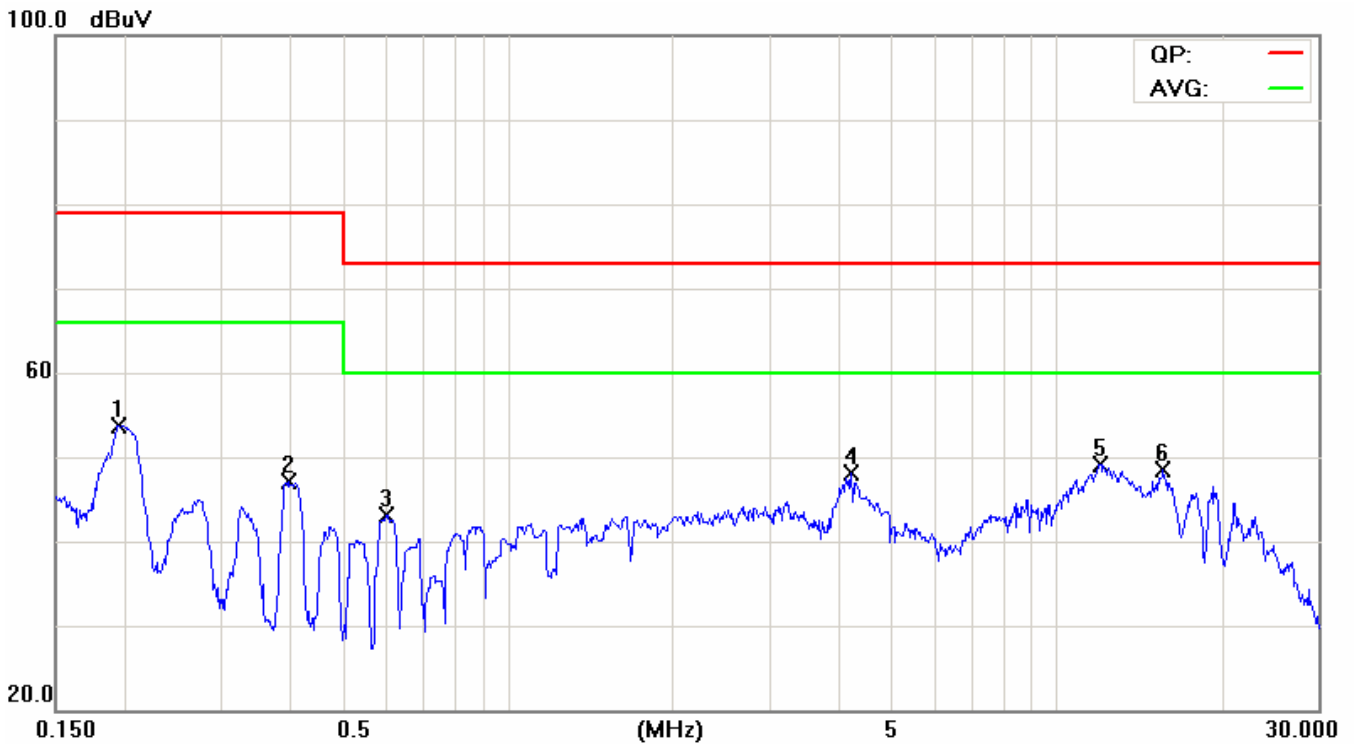

NO.	Frequency (MHz)	QuasiPeak reading (dBuV)	Average reading (dBuV)	Correction factor (dB)	QuasiPeak result (dBuV)	Average result (dBuV)	QuasiPeak limit (dBuV)	Average limit (dBuV)	QuasiPeak margin (dB)	Average margin (dB)	Remark (Pass/Fail)
1	0.1960	40.97	31.97	9.68	50.65	41.65	79.00	66.00	-28.35	-24.35	Pass
2	0.3951	23.51	12.93	9.70	33.21	22.63	79.00	66.00	-45.79	-43.37	Pass
3	0.6002	20.04	9.31	9.72	29.76	19.03	73.00	60.00	-43.24	-40.97	Pass
4	4.1908	32.21	18.15	9.74	41.95	27.89	73.00	60.00	-31.05	-32.11	Pass
5	11.9505	32.87	21.75	9.91	42.78	31.66	73.00	60.00	-30.22	-28.34	Pass
6	15.5333	32.55	21.68	9.94	42.49	31.62	73.00	60.00	-30.51	-28.38	Pass

REMARKS: L1 = Line One (Live Line)



CCS Conduction Test

Model No.	Vigor3900	Test Date	2010/10/21
Environmental Conditions	26°C, 60% RH	Test Mode	Mode 1
Tested by	Hank Wang	Line	L2

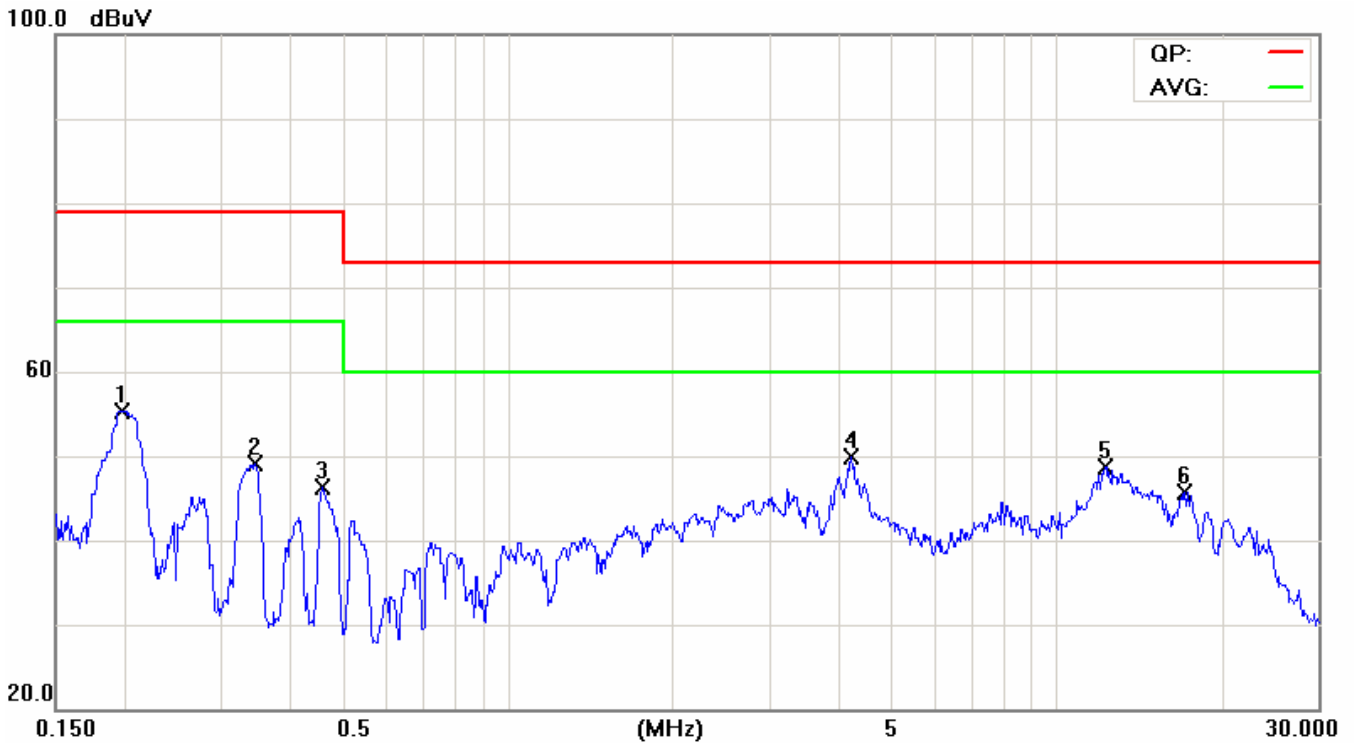

NO.	Frequency (MHz)	QuasiPeak reading (dBuV)	Average reading (dBuV)	Correction factor (dB)	QuasiPeak result (dBuV)	Average result (dBuV)	QuasiPeak limit (dBuV)	Average limit (dBuV)	QuasiPeak margin (dB)	Average margin (dB)	Remark (Pass/Fail)
1	0.1968	42.50	34.64	9.66	52.16	44.30	79.00	66.00	-26.84	-21.70	Pass
2	0.3450	36.68	25.98	9.69	46.37	35.67	79.00	66.00	-32.63	-30.33	Pass
3	0.4572	32.19	17.18	9.71	41.90	26.89	79.00	66.00	-37.10	-39.11	Pass
4	4.2204	33.80	17.02	9.75	43.55	26.77	73.00	60.00	-29.45	-33.23	Pass
5	12.2347	33.01	22.65	9.93	42.94	32.58	73.00	60.00	-30.06	-27.42	Pass
6	17.1248	31.31	18.92	9.99	41.30	28.91	73.00	60.00	-31.70	-31.09	Pass

REMARKS: L2 = Line Two (Neutral Line)



7 RADIATED EMISSION MEASUREMENT

7.1. LIMITS OF RADIATED EMISSION MEASUREMENT

According to FCC Part 15.33 (b), for an unintentional radiator, including a digital device, the spectrum shall be investigated from the lowest radio frequency signal generated or used in the device, without going below the lowest frequency for which a radiated emission limit is specified, up to the frequency shown in the following table:

Highest frequency generated or used in the device or on which the device operates or tunes (MHz)	Upper frequency of measurement range (MHz)
Below 1.75	30
1.75-108	1000
108-500	2000
500-1000	5000
Above 1000	5 th harmonic of the highest frequency or 40GHz, whichever is lower

Below 1GHz (for digital device)

FREQUENCY (MHz)	dBuV/m (At 10m)	
	Class A	Class B
30 ~ 230	40	30
230 ~ 1000	47	37

Limit tables for non-digital device:

Class A Radiated Emission limit at 10m (for others)

Frequency (MHZ)	Field Strength Limit (uV/m)Q.P.	Field Strength Limit (dBuV/m)Q.P.
30 - 88	90	39
88 - 216	150	43.5
216 – 960	210	46.4
Above 960	300	49.5

Class B Radiated Emission limit at 3m (for others)

Frequency (MHZ)	Field Strength Limit (uV/m)Q.P.	Field Strength Limit (dBuV/m)Q.P.
30 - 88	100	40
88 - 216	150	43.5
216 – 960	200	46
Above 960	500	54



Above 1GHz(for all device)

Frequency (MHZ)	Class A (dBuV/m) (At 10m)		Class B (dBuV/m) (At 3m)	
	Average	Peak	Average	Peak
Above 1000	49.5	69.5	54	74

- NOTE:** (1) The lower limit shall apply at the transition frequencies.
(2) Emission level (dBuV/m) = 20 log Emission level (uV/m).
(3) The measurement above 1GHz is at close-in distances 3m, and determine the limit **L2** corresponding to the close-in distance **d2** by applying the following relation: **L2 = L1 (d1/d2)**, where **L1** is the specified limit in microvolts per metre (**uV/m**) at the distance **d1 (10m)**, **L2** is the new limit for distance **d2 (3m)**.
So the new Class A limit above 1GHz at 3m is as following table:

Frequency (MHZ)	Class A (dBuV/m) (At 3m)	
	Average	Peak
Above 1000	60	80



7.2. TEST INSTRUMENTS

Wugu 10M Chamber				
Name of Equipment	Manufacturer	Model	Serial Number	Calibration Due
Spectrum Analyzer	Agilent	E4446A	MY48250297	10/13/2011
EMI Test Receiver	R&S	ESCI	100961	09/12/2011
EMI Test Receiver	R&S	ESCI	100962	09/12/2011
Pre-Amplifier	MITEQ	1625-3000	1490939	11/19/2011
Pre-Amplifier	MITEQ	1625-3000	1490940	11/19/2011
Pre-Amplifier	MITEQ	AFS44-00102650-42-10P-44	1415367	11/19/2011
Bilog Antenna	Sunol Sciences	JB1	A100209-2	10/07/2011
Bilog Antenna	Sunol Sciences	JB1	A100209-3	10/07/2011
Horn Antenna	EMCO	3117	00055167	12/01/2011
Turn Table	CCS	CC-T-1F	N/A	N.C.R
Antenna Tower	CCS	CC-A-1F	N/A	N.C.R
Controller	CCS	CC-C-1F	N/A	N.C.R
Site NSA	CCS	N/A	N/A	11/25/2011
Site VSWR	CCS	N/A	N/A	11/23/2011
Test S/W	EZ-EMC (CCS-3A1RE)			

NOTE: 1. The calibration interval of the above test instruments is 12 months and the calibrations are traceable to NML/ROC and NIST/USA.
2. N.C.R = No Calibration Request.



7.3. TEST PROCEDURES

(please refer to measurement standard or CCS SOP PA-031)

Procedure of Preliminary Test

- The equipment was set up as per the test configuration to simulate typical usage per the user's manual. When the EUT is a tabletop system, a wooden turntable with a height of 0.8 meters is used which is placed on the ground plane. When the EUT is a floor standing equipment, it is placed on the ground plane which has a 12 mm non-conductive covering to insulate the EUT from the ground plane.
- Support equipment, if needed, was placed as per ANSI C63.4.
- All I/O cables were positioned to simulate typical usage as per ANSI C63.4.
- The EUT received AC 120VAC/60Hz power source from the outlet socket under the turntable. All support equipment power received from another socket under the turntable.
- The antenna was placed at 3 or 10 meter away from the EUT as stated in ANSI C63.4. The antenna connected to the Spectrum Analyzer via a cable and at times a pre-amplifier would be used.
- The Analyzer / Receiver quickly scanned from 30MHz to 40GHz. The EUT test program was started. Emissions were scanned and measured rotating the EUT to 360 degrees and positioning the antenna 1 to 4 meters (For Below 1GHz) or 1 meter (For Above 1GHz) above the ground plane, in both the vertical and the horizontal polarization, to maximize the emission reading level.
- The test mode(s) described in Item 3.1 were scanned during the preliminary test:
- After the preliminary scan, we found the test mode described in Item 3.1 producing the highest emission level.
- The worst configuration of EUT and cable of the above highest emission level were recorded for reference of the final test.

Procedure of Final Test

- EUT and support equipment were set up on the turntable as per the configuration with highest emission level in the preliminary test.
- The Analyzer / Receiver scanned from 30MHz to 40GHz. Emissions were scanned and measured rotating the EUT to 360 degrees, varying cable placement and positioning the antenna 1 or 1 to 4 meters above the ground plane, in both the vertical and the horizontal polarization, to maximize the emission reading level.
- Recording at least the six highest emissions. Emission frequency, amplitude, antenna position, polarization and turntable position were recorded into a computer in which correction factors were used to calculate the emission level and compare reading to the applicable limit and Q.P. (For Below 1GHz) or Peak/Average (For Above 1GHz) reading is presented.
- The test data of the worst-case condition(s) was recorded.

7.4. TEST SETUP

Below 1GHz

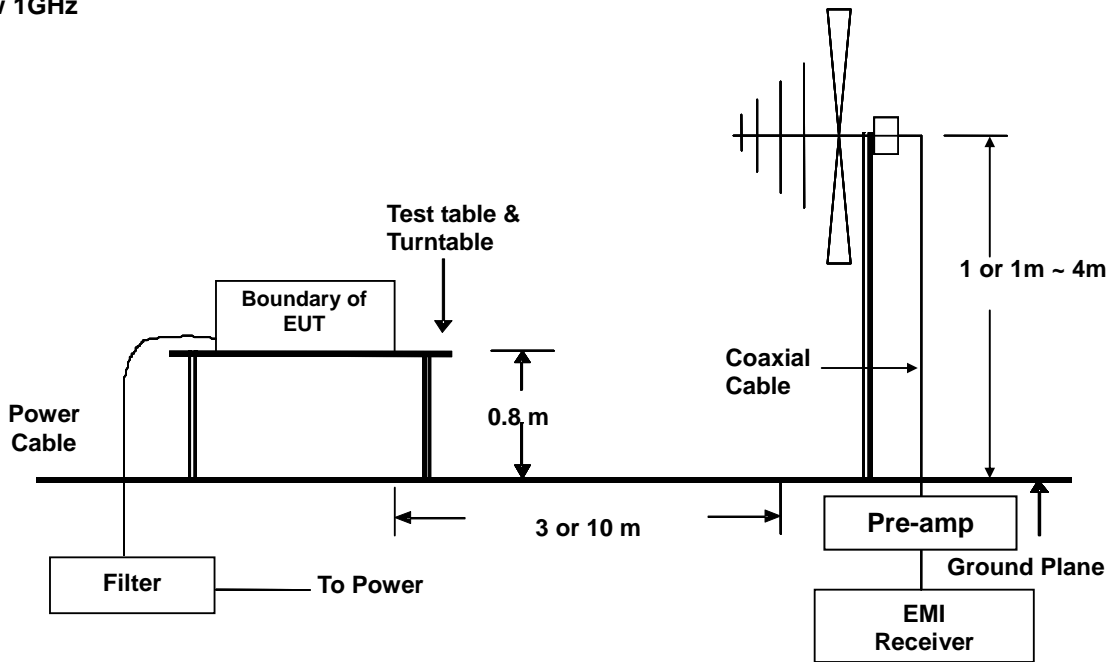

Above 1GHz

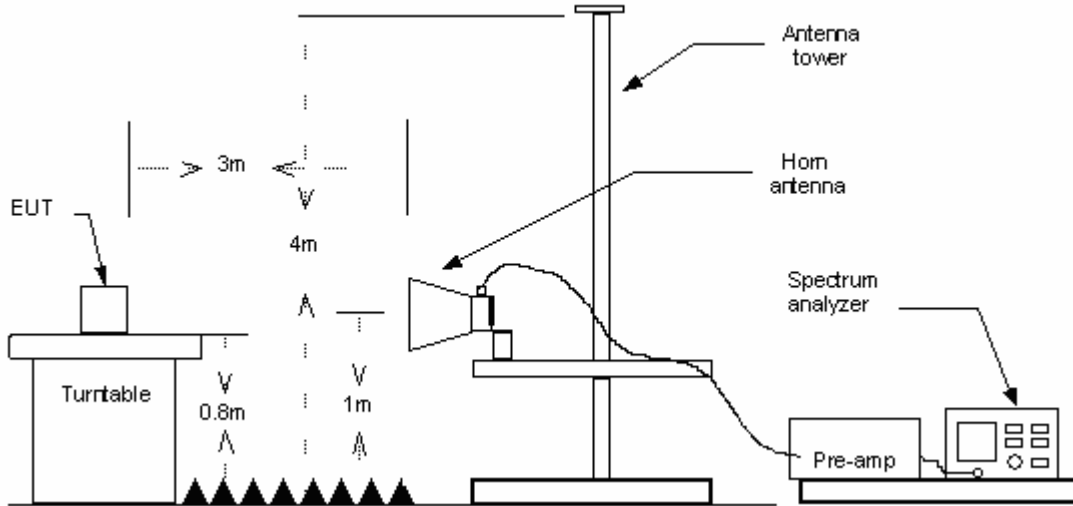

- For the actual test configuration, please refer to the related item – Photographs of the Test Configuration.



7.5. DATA SAMPLE:

Below 1GHz

Frequency (MHz)	Reading (dBuV)	Correction Factor (dB/m)	Result (dBuV/m)	Limit (dBuV/m)	Margin (dB)	Degree (°)	Height (cm)	Remark
xx.xx	16.49	9.86	26.35	30.00	-3.65	116.00	101.00	QP

Above 1GHz

Frequency MHz	Reading		Corr. Factor (dB/m)	Result		Limit		Margin (dB)	Azimuth (°)	Height (cm)	Remark
	Peak (dBuV/m)	Average (dBuV/m)		Peak (dBuV/m)	Average (dBuV/m)	Peak (dBuV/m)	Average (dBuV/m)				
xx.xx	39.34	---	0.68	40.02	---	74.00	54.00	-13.98	49.70	100.00	Peak

- Frequency (MHz) = Emission frequency in MHz
- Reading (dBuV) = Uncorrected Analyzer / Receiver reading
- Correction Factor (dB/m) = Antenna factor + Cable loss – Amplifier gain
- Result (dBuV/m) = Reading (dBuV) + Corr. Factor (dB/m)
- Limit (dBuV/m) = Limit stated in standard
- Margin (dB) = Result (dBuV/m) – Limit (dBuV/m)
- Q.P. = Quasi-Peak



7.6. TEST RESULTS

Below 1000MHz

Model No.	Vigor3900	Test Mode	Mode 1
Environmental Conditions	26°C, 60% RH	Test Date	2010/11/19
Antenna Pole	Vertical	Antenna Distance	10m
Detector Function:	Quasi-peak & Peak.	Tested by	Kevin Chang

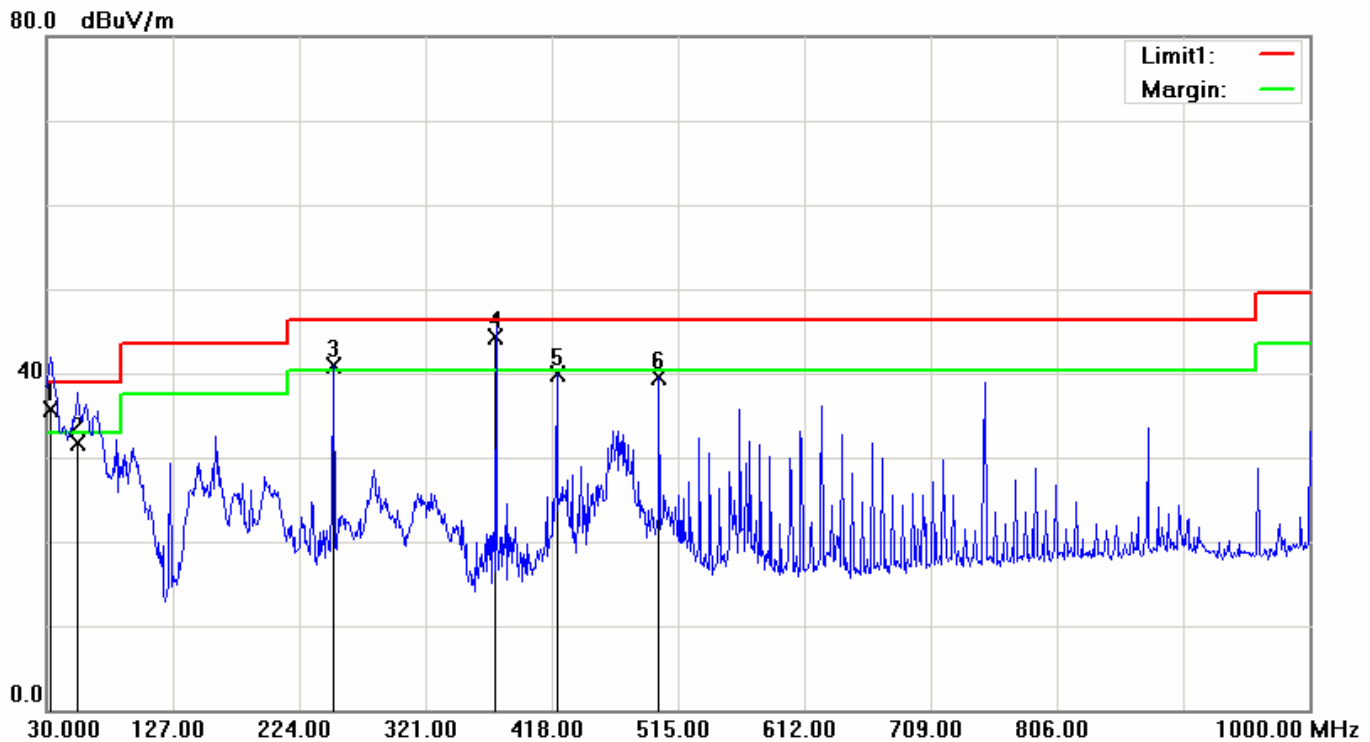

No.	Frequency (MHz)	Reading (dBuV)	Correction Factor(dB/m)	Result (dBuV/m)	Limit (dBuV/m)	Margin (dB)	Height (cm)	Degree (°)	Remark
1	32.6900	58.77	-22.97	35.80	39.00	-3.20	100	20	QP
2	54.2500	65.78	-34.14	31.64	39.00	-7.36	100	187	QP
3	250.1900	69.41	-28.47	40.94	46.40	-5.46	100	349	peak
4	375.0400	68.93	-24.61	44.32	46.40	-2.08	100	213	QP
5	421.8800	63.13	-23.16	39.97	46.40	-6.43	100	360	peak
6	500.4500	60.71	-21.14	39.57	46.40	-6.83	100	189	peak

REMARKS: 1. The other emission levels were very low against the limit.



Below 1000MHz

Model No.	Vigor3900	Test Mode	Mode 1
Environmental Conditions	26°C, 60% RH	Test Date	2010/11/19
Antenna Pole	Horizontal	Antenna Distance	10m
Detector Function:	Quasi-peak & Peak.	Tested by	Kevin Chang

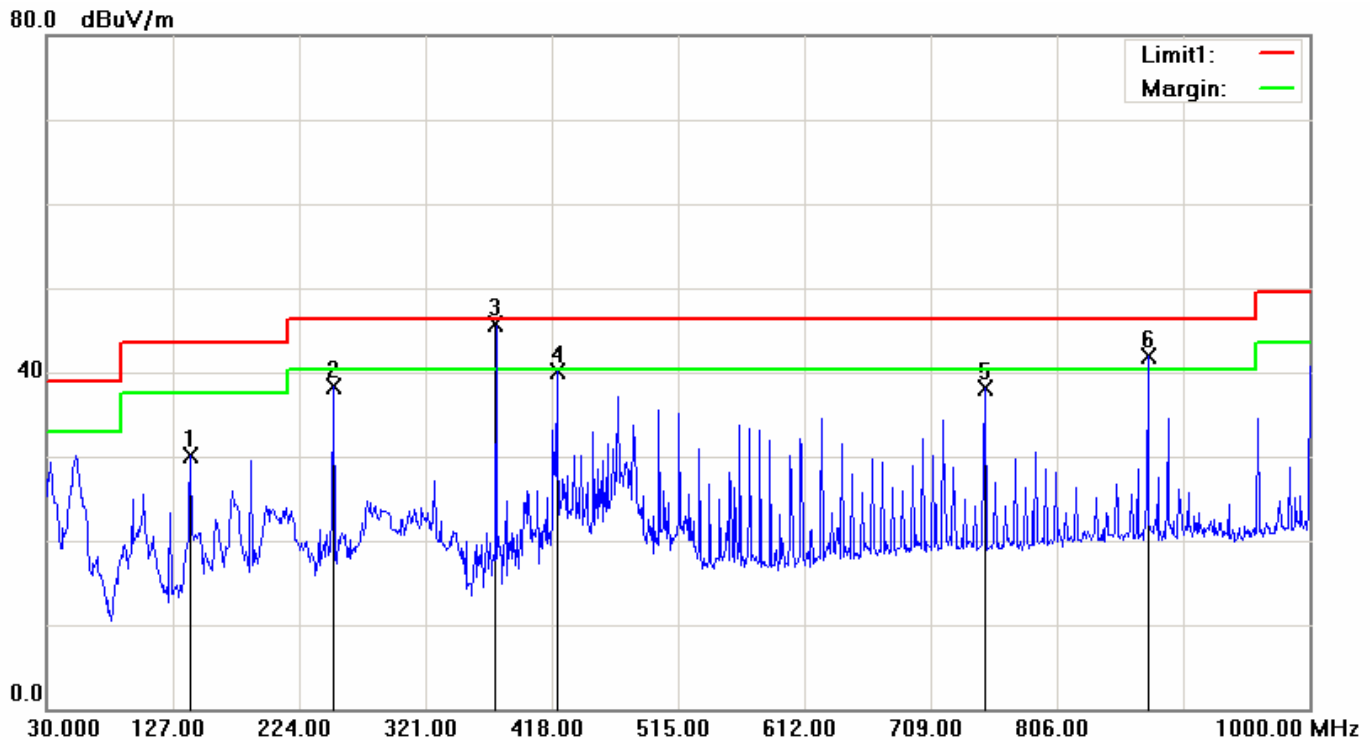

No.	Frequency (MHz)	Reading (dBuV)	Correction Factor(dB/m)	Result (dBuV/m)	Limit (dBuV/m)	Margin (dB)	Height (cm)	Degree (°)	Remark
1	140.5800	58.16	-28.09	30.07	43.50	-13.43	300	16	peak
2	250.1900	67.35	-29.04	38.31	46.40	-8.09	300	256	peak
3	375.0380	70.94	-25.25	45.69	46.40	-0.71	271	146	QP
4	421.8800	63.94	-23.82	40.12	46.40	-6.28	299	0	peak
5	750.7100	56.01	-17.98	38.03	46.40	-8.37	100	176	peak
6	875.8400	58.06	-16.13	41.93	46.40	-4.47	100	142	peak

REMARKS: 1. The other emission levels were very low against the limit.



Above 1000MHz

Model No.	Vigor3900	Test Mode	Mode 1
Environmental Conditions	26°C, 60% RH	Test Date	2010/11/19
Antenna Pole	Vertical	Antenna Distance	3m
Highest frequency generated or used	375MHz	Upper frequency	2000MHz
Detector Function:	Peak	Tested by	Kevin Chang

Frequency MHz	Reading		Corr. Factor (dB/m)	Result		Limit		Margin (dB)	Height (cm)	Azimut h (°)	Remark
	Peak (dBuV/m)	Average (dBuV/m)		Peak (dBuV/m)	Average (dBuV/m)	Peak (dBuV/m)	Average (dBuV/m)				
1247.500	68.89	---	-20.91	47.98	---	80.00	---	-32.02	400	176	peak
1500.500	65.97	---	-20.18	45.79	---	80.00	---	-34.21	200	107	peak
1632.500	65.42	---	-19.09	46.33	---	80.00	---	-33.67	100	280	peak
1918.500	62.16	---	-16.71	45.45	---	80.00	---	-34.55	300	69	peak
4646.500	58.30	---	-11.65	46.65	---	80.00	---	-33.35	400	359	peak
5251.500	58.66	---	-11.00	47.66	---	80.00	---	-32.34	400	165	peak

REMARKS:

1. The other emission levels were very low against the limit.
2. Average test would be performed if the peak result were greater than the average limit.
3. Data of measurement within this frequency range shown " --- " in the table above means the reading of emissions are attenuated more than 20dB below the permissible limits or the field strength is too small to be measured.
4. $Margin (dB) = Result (dBuV/m) - Limit (dBuV/m)$



Model No.	Vigor3900	Test Mode	Mode 1
Environmental Conditions	26°C, 60% RH	Test Date	2010/11/19
Antenna Pole	Horizontal	Antenna Distance	3m
Highest frequency generated or used	375MHz	Upper frequency	2000MHz
Detector Function:	Peak	Tested by	Tony Tsai

Frequency MHz	Reading		Corr. Factor (dB/m)	Result		Limit		Margin (dB)	Azimuth (°)	Height (cm)	Remark
	Peak (dBuV/m)	Average (dBuV/m)		Peak (dBuV/m)	Average (dBuV/m)	Peak (dBuV/m)	Average (dBuV/m)				
1247.500	68.89	---	-20.91	47.98	---	80.00	---	-32.02	400	176	peak
1500.500	65.97	---	-20.18	45.79	---	80.00	---	-34.21	200	107	peak
1632.500	65.42	---	-19.09	46.33	---	80.00	---	-33.67	100	280	peak
1918.500	62.16	---	-16.71	45.45	---	80.00	---	-34.55	300	69	peak
4646.500	58.30	---	-11.65	46.65	---	80.00	---	-33.35	400	359	peak
5251.500	58.66	---	-11.00	47.66	---	80.00	---	-32.34	400	165	peak

REMARKS:

1. The other emission levels were very low against the limit.
2. Average test would be performed if the peak result were greater than the average limit.
3. Data of measurement within this frequency range shown " --- " in the table above means the reading of emissions are attenuated more than 20dB below the permissible limits or the field strength is too small to be measured.
4. $Margin (dB) = Result (dBuV/m) - Limit (dBuV/m)$



8 PHOTOGRAPHS OF THE TEST CONFIGURATION CONDUCTED EMISSION TEST





RADIATED EMISSION TEST

Below 1GHz





Above 1GHz

